

Original Operating Manual EN

HTS-2/M/ZIRKON-120



Friedrich-List-Straße 8
D-76297 Stutensee-Blankenloch
GERMANY
Phone: +49 (0) 7244 708710
www.mihm-vogt.de

Contents

1	General Information	5
1.1	Product Name and Type Designation.....	5
1.2	Manufacturer Information.....	5
1.3	Limitation of Liability	5
1.4	Operator's Responsibility.....	5
1.5	Documentation	6
1.6	Symbols and Notes	6
1.7	Security.....	7
1.8	Target groups and personnel requirements	8
1.9	Customer requirements for the installation location	9
1.9.1	Mechanical and fire protection requirements.....	9
1.9.2	Electrical requirements.....	10
1.10	Device life cycles	10
1.11	Intended use.....	11
1.12	Predictable misuse	11
1.13	Warning signs on the device	11
1.14	Personal protective equipment.....	12
1.15	Special safety instructions	12
1.15.1	Transport and equipment installation.....	12
1.15.2	Packaging and storage	13
1.15.3	Cleaning, Care, and Maintenance.....	14
1.15.4	Decommissioning, dismantling, disposal	14
1.16	Emergency procedures.....	15
1.17	Operator's duty of care.....	15
1.18	User's duty of care	16
1.19	Regular inspections	16
2	Product description	17
2.1	General function of the device	17
2.2	Components	17
2.3	Device Data	18
2.3.1	Nameplate.....	18
2.3.2	Technical Data	18
3	Transport, packaging, and storage	20
3.1	Requirements for the executing personnel.....	20

3.2	Lifting and transporting	20
3.3	Storage.....	20
3.4	Limits for operation and storage.....	20
3.5	Packaging	21
3.5.1	Unpacking.....	21
3.5.2	Disposing of the packaging.....	21
4	Setup and installation	22
4.1	Requirements for executing personnel	22
4.2	Requirements for the installation location.....	22
4.3	Setting up the device	22
5	Commissioning	24
5.1	Requirements for the executing personnel.....	24
5.2	Turning on the device	24
5.3	Turning off the device	24
5.4	Permissions.....	24
5.5	Setup	24
5.5.1	Heating Chamber and Door Insulation.....	24
6	Operation	25
6.1	Controls and displays.....	25
6.1.1	Row selection	26
6.2	Information screen.....	26
6.3	Turn on the device.....	27
6.4	Basic settings program controller.....	27
6.4.1	Switching the country-specific current limit from 15A to 13A	28
6.5	Commissioning	29
6.5.1	Requirements for the executing personnel.....	29
6.5.2	Safety instructions for operation.....	29
6.5.3	Sinter aids	29
6.5.4	Sintering	29
6.5.5	Autostart timer function.....	39
6.5.6	Loading and renaming saved programs	40
6.5.7	Serviceprogramme	42
7	Declaration of conformity	43
8	Care and maintenance	45
8.1	Requirements for the Operating Personnel.....	45
8.2	Maintenance Schedule	45

9	Malfunctions and error messages	46
9.1	Malfunctions	47
9.2	Electronics error messages	47
10	Technical drawings	48

1 General Information

1.1 Product Name and Type Designation

Product Name: HTS-2/M/ZIRCON-120
Item Number: REF: 7202000002

1.2 Manufacturer Information

Name: Mihm-Vogt GmbH & Co. KG
Address: Friedrich-List-Strasse 8
76297 Stutensee-Blankenloch, GERMANY
E-Mail: info@mihm-vogt.de
Phone: +49 7244 / 70871-0

1.3 Limitation of Liability

The content of this operating manual has been created in accordance with applicable laws and standards. The device was developed using the latest state-of-the-art technology.



NOTE

The manufacturer assumes no liability for damages resulting from:

- ▶ Ignoring or disregarding the operating instructions.
- ▶ Intentional or grossly negligent misuse.
- ▶ For non-prescribed use.
- ▶ Use of untrained personnel.
- ▶ Use of non-specialists (e.g., during maintenance work, etc.).
- ▶ Technical modifications to the device that have not been discussed with and approved by the manufacturer.
- ▶ Use of spare parts is not approved by the manufacturer.

1.4 Operator's Responsibility

The device is intended for commercial use. Therefore, the operator is subject to legal occupational safety obligations. In addition to the safety instructions in this operating manual, the safety, accident prevention, and environmental protection regulations applicable to the device's area of use must be observed.

This applies especially to:

- The operator must familiarize themselves with the applicable occupational safety regulations.
- The operator must ensure that all employees who handle the device have read and understood this operating manual.
- Furthermore, he must regularly train the staff and inform them about any potential hazards when handling the equipment.
- The operator must provide the staff with the necessary personal protective equipment.
- The operator must regularly have all safety devices checked to ensure they are fully functional and complete.

1.5 Documentation

Content and Structure of the Operating Manual

This operating manual is an integral part of the device. It contains hazard warnings, instructions, and information for the proper and safe handling of the device and must be accessible to every user throughout the entire lifespan of the device. This manual is intended for trained professionals.

1.6 Symbols and Notes

Labeling concept for integrated texts and references.

The following types of notices are used:



DANGER

An imminent danger that could lead to serious bodily injury or death.



WARNING

A potentially dangerous situation that could lead to serious bodily injury or death.



CAUTION

A potentially dangerous situation that could lead to minor bodily injuries.



NOTE

A potentially harmful situation in which the product or an object in its surroundings could be damaged.

NOTE

Tip/Hint for easier operation.

If you have any questions, please contact the following address:



Friedrich-List-Straße 8
D-76297 Stutensee-Blankenloch
GERMANY
Phone: +49 (0) 7244 70871-99
service@mihm-vogt.de
www.mihm-vogt.de

1.7 Security

This device is a high-temperature furnace (sintering furnace) intended for commercial use in dental laboratories and must only be used for sintering interable ceramics. The safety instructions in this document are designed to prevent personal injury and property damage, and they apply to the device and its associated accessories as described here. Please read and follow the instructions in this operating manual to use the device safely. Do not perform any unauthorized modifications or repairs on the device. As the operator, you are responsible for ensuring that all safety instructions are observed and complied with, and that everyone working on or with the device has fully read and understood this operating manual. Make sure that the following tasks are carried out only by qualified professionals:

- Setup and Installation
- Installation and Connection
- Commissioning and Operation



DANGER

Electricity!

Danger to life from electric shock.

- ▶ Do not touch live cables and components with wet hands.
- ▶ Work on household and device electrical systems must only be carried out by qualified and authorized electrical professionals!
- ▶ Follow safety regulations when working with electrical current.
- ▶ Before starting installation, maintenance, cleaning, or repair work, disconnect the device from the power supply and secure it against being switched back on.



DANGER

Warning: Risk of Inflammation!

Danger to life from using flammable or explosive materials or substances in the oven area.

- ▶ Do not operate the device near easily flammable sources or objects.
- ▶ Adequate ventilation must be ensured at the installation site to dissipate heat and any possible exhaust gases.



WARNING

Burn hazard due to hot surfaces!

- ▶ During device operation, hot surfaces develop and touching them can cause burns.
- ▶ Do not touch the casing or oven door while it is operating.
- ▶ Do not reach the heating chamber. It may still be very hot from the previous heating cycle.
- ▶ Before performing maintenance, cleaning, or repairs, make sure to let the device cool down completely.
- ▶ Wear heat-resistant safety gloves when working on hot components.
- ▶ Use an appropriate, sufficiently long sampling tool for inserting and removing sintered material.



CAUTION

Incorrect operation!

No liability will be accepted for damages resulting from misuse, incorrect operation, wrong connection, or improper maintenance/repair by untrained personnel. Furthermore, all warranty services will be voided in such cases. If the device or power cable is damaged or no longer functions properly, the device must not be used anymore. In this situation, please contact your service partner immediately.

- ▶ For your own safety and to ensure the longevity of your device, use only original spare parts. In addition to the instructions in this user manual, local regulations (e.g., accident prevention rules) also apply to the safe operation of the device, which the device operator must provide to the users.
- ▶ Clear and easy-to-read safety signs must be posted at the workplace.



NOTICE

Before starting up or performing any work on or inside the device, every operator must read and understand the operating manual.

- ▶ Keep the user manual carefully for the entire lifetime of the device.

1.8 Target groups and personnel requirements

This operating manual is intended for the following personnel:

- **Skilled worker for mechanical tasks**

Mechanical work must only be carried out by a qualified professional with appropriate training. Qualified professionals are individuals familiar with the assembly, mechanical installation, commissioning, troubleshooting, and maintenance of the product.

- **Specialist for electrotechnical work**

An electrical specialist, thanks to their professional training, knowledge, and experience, as well as familiarity with the relevant standards and regulations, can perform work on electrical systems and independently identifying and avoiding potential hazards. The electrical specialist is specifically trained in the work environment in which they operate and is well-versed in the applicable standards and regulations. They are qualified in the field of electrical engineering according to the nationally applicable regulations.

- **Operator**
The operator was informed by the supervisor during a briefing about the tasks assigned to him and the potential hazards that may arise from improper behavior. Tasks that go beyond normal operation may only be performed by the operator if they are specified in this manual and the supervisor has explicitly authorized him to carry them out.
- **Instructed person**
The instructed person has been verifiably informed by the operator in a training session about the tasks assigned to them and the potential hazards in case of improper conduct.

1.9 Customer requirements for the installation location

1.9.1 Mechanical and fire protection requirements

- The setup location (floor or table) must be level and capable of supporting a load at least equal to the device's weight including accessories and contents, see section 2.3.2 Technical Data.
- The surfaces, materials, nearby objects like trash bins, etc., and the flooring of the installation site must be non-flammable (fire protection class A DIN 4102).
- Adequate ventilation and air exchange at the installation site must be ensured.
- To prevent heat buildup around the sintering furnace, minimum distances of A continuous 100 mm is required.
- No flammable or combustible items should be near the device.

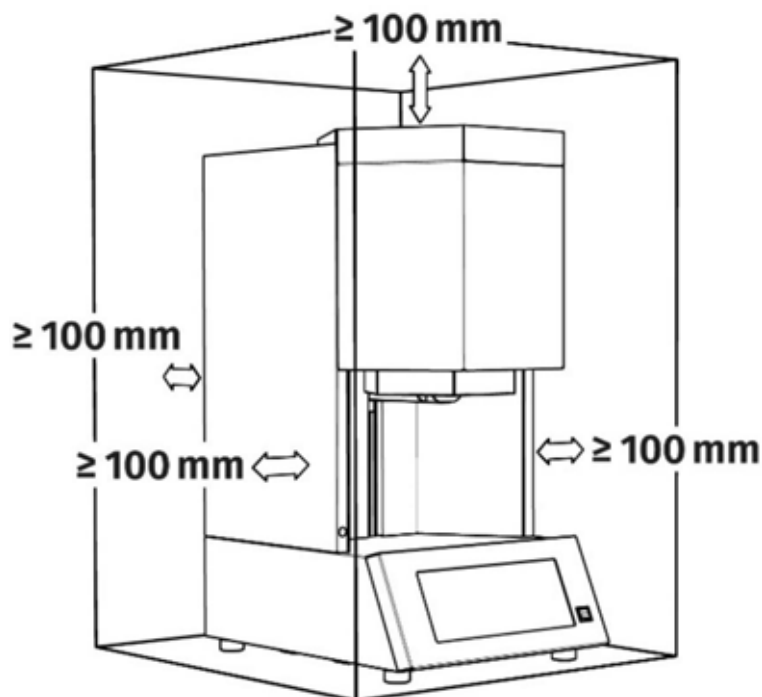

1.9.2 Electrical requirements

Requirements for the customer-side home installation:

- The device requires its own dedicated electrical circuit.
- The circuit must be equipped on the building side with a circuit breaker of at least 16 A, type K or Z (other types of fuses depending on the country of use).
- An additional RCD (designed for a 30mA trip current) must be installed.
- The device requires a protective earth connected at the socket for electrically safe operation.
- When choosing the installation location, please note that the included power cord is 2.0 meters long and the use of extension cables is not allowed.
- The supply voltage must be within the mains voltage range of 200-240 V.
- Access to the power outlet must always be guaranteed.



NOTICE

Risk of device damage due to incorrect power voltage.

- ▶ Check the mains voltage before connecting and starting up.
- ▶ Compare the mains voltage with the values on the nameplate.

1.10 Device life cycles

- **Delivery**
Compare the completeness of the delivery with the delivery note immediately upon receipt. Inspect the delivery immediately upon receipt for any transport damage. Report any transport damage right away to the shipping company and MIHM-VOGT GmbH & Co. KG. If damage is found, do not proceed with assembly, installation, or commissioning.
- **Transport to the installation site**
Transport must be carried out using a suitable floor conveyor vehicle. During this process, the load must be prevented from shifting or tipping, see section 3.
- **Storage**
The device must not be stored outdoors or in damp areas; see section 3.
- **Unpacking:** Please refer to the separate unpacking instructions included with the device or available for download at www.mihm-vogt.de.
- **Editing**
Installation must only be carried out by trained professionals or authorized service partners, see section 4.
- **Operation**
Manual loading and unloading of the furnace. Automatic process control, see section 5.
- **Care and maintenance, see sections 8 and 1.15.3.**
- **Disassembly**
Disassembly may only be carried out by trained personnel or authorized service partners, see 1.15.4.
- **Waste disposal**
Proper disposal in accordance with the applicable legal regulations, see 1.15.4.

1.11 Intended use

This device is a high-temperature furnace designed for professional use in dental laboratories and must only be used for sintering sinter-capable ceramics.



NOTE

No liability can be accepted for any damage to persons or property caused by misuse, incorrect operation, or improper maintenance and repair by untrained personnel. In such cases, any warranty claims are void.

Using replacement and wear parts that are not sourced from the manufacturer voids the device's approval and warranty.

1.12 Predictable misuse

The device must not be used for any purpose other than its intended use. The following actions can cause serious damage or misuse, pose a danger, and must therefore be strictly avoided:

- Independent modifications or repairs not approved by the manufacturer.
- Use of spare parts and products that are not approved by the manufacturer.
- Operation of the device by unauthorized personnel.
- Operating a damaged device.
- Ignoring safety instructions or accident prevention regulations.
- A use that does not comply with the declaration of conformity.

1.13 Warning signs on the device

The device has the following warning signs attached:



DANGER

Caution: Hot surface, risk of burns!

- ▶ If the oven door opens automatically at high temperatures due to the program, there's a risk of burns.
- ▶ Beware of hot surfaces.
- ▶ Always wear personal protective equipment.



DANGER

Caution, Danger!

- ▶ Read and follow the operating instructions before starting up.
- ▶ Counter the general hazard by following the appropriate safety measures, such as wearing personal protective equipment.
- ▶ Please pay attention to the prevailing accident prevention regulations.

1.14 Personal protective equipment



Protective Gloves
Wear heat-resistant gloves



Safety Work Shoes
Wear safety shoes



Safety goggles
Wear safety goggles



Respiratory protection mask
Wear a respiratory mask

1.15 Special safety instructions

1.15.1 Transport and equipment installation

Follow the general accident prevention regulations for Germany! For use in other countries, comply with the respective national accident prevention regulations.



DANGER

Danger of Injury!

- ▶ Avoid dropping, sliding, or tipping the device!
- ▶ Carry/hold the device only by the bottom edge of the casing (base) with both hands.



CAUTION

Risk of injury from equipment weight!

Physical overload/back pain caused by heavy carrying weight.

- ▶ Carry/move the device with at least 2 people (maximum carrying weight: 30 kg per person).



NOTICE

Transport damage! To avoid personal injury, property damage, and costs:

- ▶ Always transport the device in an upright position.
- ▶ Never stack two devices on top of each other.
- ▶ Do not place any objects on the device or its packaging.
- ▶ To avoid damage, transportation should be as shock- and vibration-free as possible.
- ▶ Make sure the device is secure against slipping and tipping over during transport.
- ▶ When using the device, gloves (to prevent slipping and cuts) and safety shoes (to protect feet from injuries caused by falling loads) must be worn.
- ▶ Check the goods immediately upon receipt for any damage and completeness. Report any defects to the carrier without delay and have them confirmed on the freight bill by the carrier. Mihm-Vogt GmbH & Co. KG accepts no liability for defects or losses discovered later.

1.15.2 Packaging and storage



NOTE

The packaging protects the device from transport damage, corrosion, and other types of harm.

- ▶ Store the device only in its packaging.
- ▶ Keep the device's packaging dry and dust-free for future reuse.
- ▶ Store the device only in environments with temperatures ranging from -40°C to 70°C.
- ▶ Store the device in a dry, dust-free place.
- ▶ Avoid direct sunlight on the device.
- ▶ Avoid mechanical shocks.

1.15.3 Cleaning, Care, and Maintenance

The device casing should only be cleaned gently with a damp, lint-free cloth using water-based, solvent-free cleaners. Never use abrasive materials. Always make sure to completely remove any cleaning residues.

The following device components must be cleaned with the appropriate cleaning agent:

Component:	Cleaning Process/Cleaning Agents:
Outer housing:	Damp, lint-free cloth / solvent-free cleaner
Stainless steel parts:	Lint-free cloth / stainless steel cleaner
Heating Chamber:	Dry vacuum cleaner
Controller:	Damp, lint-free cloth / solvent-free cleaner



DANGER

Danger of death from electric shock.

- ▶ Always switch off the device and let it cool down before cleaning (turn the main switch to 0 = Off) and unplug the power cord.
- ▶ Never pour or spray water or clean liquids on the device, inside or out.
- ▶ Never clean the device with a high-pressure washer or a wet vacuum cleaner.
- ▶ Before turning the device back on, make sure it is completely dry.



NOTE

Personal protective equipment must be worn during all work on the device to prevent accidents and health hazards.



NOTE

Heating system damage!

- ▶ Make sure the heating chamber stays clean, dry, and free from any mechanical damage. The insulation, heating elements, or thermocouple could get damaged.

1.15.4 Decommissioning, dismantling, disposal

Decommissioning and dismantling

Decommissioning can occur for two reasons:

- Recommissioning at a different operating location.
- With the goal of final disposal.

1. Turn off the device using the main switch (O = OFF)
2. Disconnect the device from the power supply.

Disposal



WARNING

Release of harmful substances! When handling insulating materials, pollutants can get into the air you breathe.

- ▶ Personal protective equipment (respiratory protection) must be worn during disposal.



WARNING

Damage to the environment and groundwater due to improper handling Disposal!

- ▶ When disposing of device components, the regulations and guidelines of the legislation in the operator's country must be followed.

1. Separate the components of the device into recyclables, hazardous materials, and operating supplies.
2. Dispose of the non-recyclable parts of the device properly and send the recyclable components back into the recycling loop.

1.16 Emergency procedures

- In case of emergency, switch the main switch to position O = OFF/ON and unplug the power cord.
- Let the oven cool down to room temperature with the door closed.



NOTICE

- ▶ In case of emergency, switch the main power switch on the device to O = OFF.
- ▶ In an emergency, the device must be completely shut down by unplugging it from the power outlet.
- ▶ To ensure a quick shutdown in an emergency, the power outlet and plug must always be easily accessible.

1.17 Operator's duty of care

The device is used in commercial settings. Therefore, the operator of the device is subject to legal obligations to ensure workplace safety.

In addition to the safety instructions in this operating manual, all safety, accident prevention, and environmental protection regulations applicable to the device's area of use must be followed.

In particular, the following applies:

- The operator must familiarize themselves with the applicable occupational safety regulations.
- The operator must ensure that all employees handling the device have read and understood this operating manual.
- Furthermore, he must regularly train the staff and inform them about the potential hazards that may arise when handling the equipment.
- The operator must provide the staff with the necessary protective equipment.

- The operator must regularly have all safety devices checked to ensure they are fully functional and complete.

1.18 User's duty of care

For safe operation, the user of the machine must fulfill the following obligations:

- Read and follow the operating manual and safety instructions.
- Check the device, especially the power cord and the heating chamber, for any visible damage. Report any damage immediately and do not turn on the device if it is damaged.
- Keep the device and the workspace clean.
- Wear the necessary protective gear.

1.19 Regular inspections

For safe operation, the device must be regularly maintained by the operator:

- All maintenance tasks described in the maintenance plan must be carried out, see section 8.2.
- Missed or delayed maintenance can cause follow-up damage to the equipment.

2 Product description

2.1 General function of the device

The device is used for processing sinterable ceramics.

The sintered material is placed in the sintering bowl (or similar), which is then set on the support disc on the oven door. After entering the heating parameters and pressing the "Start Stop" button, the electrically operated oven door closes, and the heating process begins.

Once the heating program has finished, the oven door automatically opens, and the finished product can be removed in accordance with safety guidelines.

Combustion chamber

The product is sintered in the heating chamber. It consists of two different ceramic insulation layers and is operated with molybdenum disilicate (MoSi_2) heating elements. The outer insulation layer is designed for temperatures up to 1200°C , while the inner one can handle temperatures up to 1700°C .

Oven door

The oven door consists of a three-part ceramic door panel. A safety switch cuts off the heating current as soon as the oven door is opened.

A slip clutch used in the drive mechanism prevents excessive pressure between the oven door and the heating chamber.

Oven Housing

The oven casing is made of sheet steel and is powder-coated with plastic both inside and out.

Program Controller

Operating parameters and heating programs are stored in non-volatile memory and remain intact even during a power outage.

The set target temperature is maintained with an accuracy of $\pm 1^\circ\text{C}$.

A temperature sensor integrated into the heating chamber measures the chamber temperature near the sintered material.

A thermocouple break protection prevents the device from overheating due to a faulty temperature sensor.

The program controller features a finish time setting based on the day of the week and time of day. The start time is automatically calculated so that the heating process finishes exactly when desired, allowing the sintered goods to be taken out on time.

2.2 Components

The device consists of the following main components:

- Program controller
- Heating chamber (HZK)
- Energy module
- Turbine unit
- Device housing

2.3 Device Data

2.3.1 Nameplate

The nameplate is located on the back of the device:



- | | |
|-----------------------------|---|
| ① Designation - Device Type | ⑧ Serial Number |
| ② Operating Voltage | ⑨ Country of Manufacture and Year of Production |
| ③ Grid Frequency | ⑩ Manufacturer's Address |
| ④ Performance | ⑪ Disposal Symbol |
| ⑤ CE/EAC Marking | ⑫ Warning icon:
Operating Instructions and
Follow all safety regulations. |
| ⑥ Item Number Mihm-Vogt | |
| ⑦ QR Code | |

2.3.2 Technical Data

General Information

Dimensions (W × D × H):	390 x 500 x 790 mm
Combustion chamber volume:	2 Sintered Cups Ø 120 x H 30 mm
Max. Temperature:	1650 °C
Weight:	60 kg
Minimum distance from the device:	All around: 10 0mm

Electrical connection values

Power Supply:	200 - 24 0V (10% tolerance)
Frequency:	50/60 Hz
Max. Power Consumption:	3.2 KW (3200 W)

Backup

On the device side:	16 AT
On the construction side:	Connection of a separate circuit with 16A type K, Z , including an RCD (residual current device). (different types of fuse s depending on the respective country of use)
Protection class:	I P 20 (Protected against solid objects, but not against water ingress)

Operating Conditions

Setup area:	In door area (in dry rooms)
Temperature range:	+5 to + 40°C
Relative humidity:	Up to 31°C: 80%
Maximum humidity:	Up to 40 °C : 50% no condensation
Geographical altitude:	Max. 20 00m ab o ve sea level
Degree of pollution:	2

3 Transport, packaging, and storage

3.1 Requirements for the executing personnel

Transportation and storage should only be handled by trained personnel.

3.2 Lifting and transporting

Because of the device's weight, lifting and carrying must be done by at least two people or with appropriate lifting equipment. For safe handling, always grip the device from the bottom with both hands and wear slip-resistant gloves and safety shoes.

3.3 Storage

The device must be stored exclusively indoors on a flat and stable surface. Additionally, the following specifications must be met:

Characteristic parameter	Unit	Value
Max Temperature	[°C]	+70
Min. Temperature	[°C]	-40
Humidity (Range)	[%]	10-90
Air Pressure (Range)	[hPa]	500-1060

Additionally, the following packaging symbols must also be observed for storage:

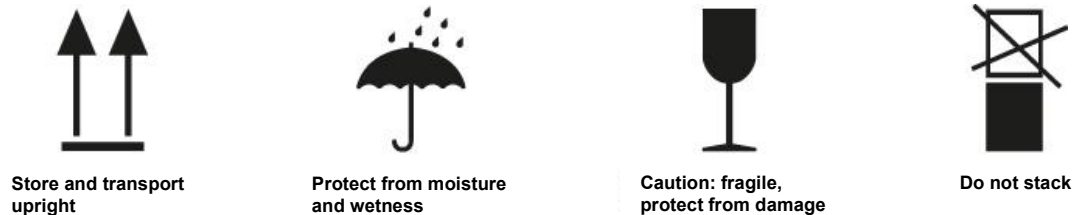

3.4 Limits for operation and storage

Operating limits

- The device does not work or malfunctions due to insufficient power supply.
- Improper loading of the stove can cause the device to malfunction or damage the heating chamber.

Storage limits

To avoid damage caused by improper storage:

- Store the device only at temperatures between -40 °C and +70 °C.
- Always keep the device dry and dust-free.
- Avoid direct sunlight.
- Avoid mechanical shocks and vibrations.

3.5 Packaging

The device is delivered in a cardboard box on a wooden pallet (according to IPPC- ISPM15 standard). Additionally, the device is protected with foam padding on the top and bottom and wrapped in PE film.

3.5.1 Unpacking

Open the packaging according to the unpacking instructions (including with the device or available for download at www.mihm-vogt.de).

3.5.2 Disposing of the packaging

Dispose of the packaging properly and in accordance with regulations. Please observe the applicable national or local rules for recycling valuable materials.

4 Setup and installation

4.1 Requirements for executing personnel

Setup and installation must only be carried out by trained specialists or an authorized service partner.

4.2 Requirements for the installation location

The device must only be placed indoors on a flat, solid, and non-flammable surface, complying with the requirements under section 1.9.1.

4.3 Setting up the device

The device is designed as a tabletop unit. Place the device on a flat surface of at least 60 x 60 cm, capable of supporting a minimum weight of 80 kg. The device must stand securely and stably on all 4 device feet.

Setup conditions:

Also, please note the environmental conditions specified under section 2.3.2 for operation:

- The operating room must be dry and dust-free.
- No liquids are allowed to enter or come into contact with the device.
- The humidity in the operating room shouldn't be too high.
- No easily flammable materials, gases, or liquids are allowed in the operating room.
- Do not store any flammable or combustible materials near the device.
- Position the device so that there is a safety clearance of at least 100mm all around to ensure sufficient cooling, see also section 1.9.1.



DANGER

Risk of injury from falling equipment!

- ▶ Ensure the device's stability!
- ▶ Make sure the surface is clean and level, and that the setup area can support the required weight.
- ▶ Please observe the installation instructions and operating conditions outlined in section 2.3.2



CAUTION

Fire hazard!

Inflammation of adjacent surfaces or flooring caused by shattering hot sinter crust or glowing sinter beads.

- ▶ Watch out for non-combustible surfaces and floor coverings.
- ▶ Do not store flammable materials near the device.



CAUTION

Danger of overheating!

Overheating caused by covered or clogged air intakes.

- ▶ Make sure the ventilation slots on all sides remain clear and are not covered.

Electrical Connection

Please note the requirements for the customer's electrical home installation under section 1.9.2.



DANGER

Electric Energy!

Danger of death due to electric shock.

- ▶ Do not touch live cables or components with wet hands.
- ▶ Follow the safety rules when working with electricity.
- ▶ Only connect the device to a power supply that matches the specifications on the device's rating plate.

5 Commissioning

5.1 Requirements for the executing personnel

Commissioning may only be carried out by trained specialists or an authorized service partner.

5.2 Turning on the device

1. Plug in the power cord.
2. Turn on the device using the main switch, I = ON



5.3 Turning off the device

Turn off the device using the main switch, O = OFF.

5.4 Permissions

Only the operator, trained professionals, or an authorized service partner are allowed to commission the device.

5.5 Setup

5.5.1 Heating Chamber and Door Insulation

When commissioning for the first time, the transport lock must first be removed and the door insulation installed.

Follow these steps:

1. When you first switch on the lift, the door will automatically open. Then, remove the transport lock.
2. Check the heating chamber and heating elements for damage.
3. Insert the door insulation as described and shown in the picture below into the door.



WARNING

Release of harmful substances! When handling insulating materials, toxic substances can get into the air you breathe.

- ▶ When handling insulation materials, personal protective equipment (respiratory protection) must be worn.

Installing the door insulation

1. Insert the connecting pins **2** into the base carrier **1**.
2. Place the door overlay **3** onto the base carrier **1** fix it using the 3 connecting pins **2**.
3. Insert the alignment pin **4** into the center bore.
4. Place the thrust washer **5** on the support **3** with the centering hole facing down, so that the centering pin fits into the hole.
5. Insert the fully assembled door insulation into the lift door.

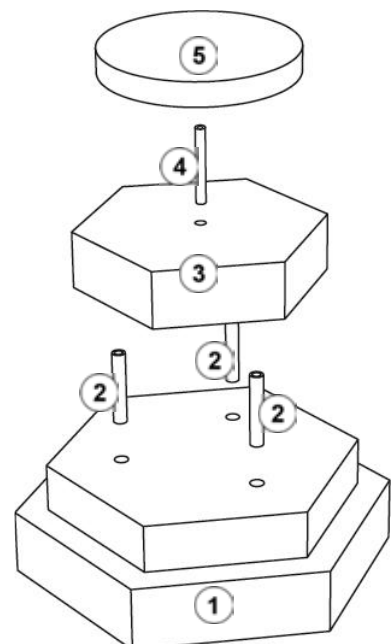

6 Operation

6.1 Controls and displays





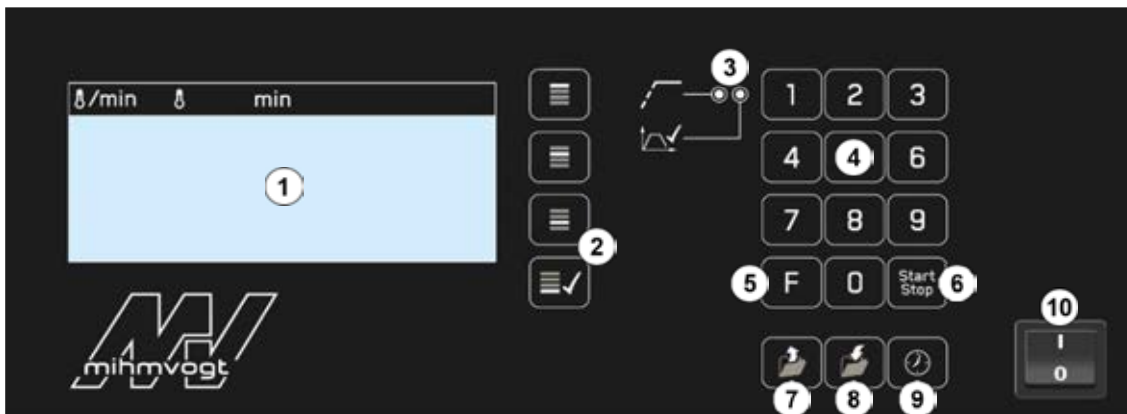

The program controller allows a wide variety of heating profiles with high precision. Operation is menu-driven via a membrane keypad. Parameters and menu sequences are displayed on a four-line LCD screen.

The program controller has the following controls:



- ① Display
- ② Press the "Select Display Line" button using the "Checkmark" key
- ③ Status LED (left: heating/holding phase, right: program end)
- ④ Numeric keypad
- ⑤ Taste "F" (Function)
- ⑥ Taste "Start Stop"
- ⑦ Taste "Load program"
- ⑧ Taste "Save program"
- ⑨ Enter "Autostart timer"
- ⑩ Main switch

Switch and Button Functions

-  Main switch ON (I) / OFF (O) for turning the device on and off.
-  Press line key 2-4 to select the corresponding display line (2-4).
-  Line key 1 or "Confirmation" ("Checkmark" key).
-  Press "Numeric input" (numeric keypad) to enter numbers.
-  Press the "Autostart timer" button to program the timer.
-  Press "Start Stop" to kick off or pause the process.



Press "Save program" to back up a program.



Press the "Program load" button to call up a program from memory.



Press the "F" button to enter the basic settings (see 6.4). In the menu item "Save Program," letters of the alphabet can be selected using the "F" button.



Additional function: Open and close the oven door. This function is only active when the current oven temperature is lower than the temperature set at the last stage (or when the oven temperature is below 300°C).

6.1.1 Row selection

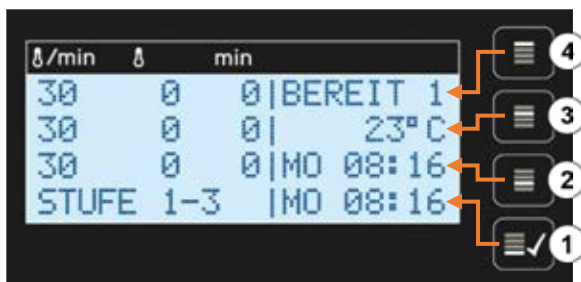

- ① Selection button for entering parameters in line 1 or to confirm input ("Checkmark" button)
- ② Selection button for entering parameters in line 2
- ③ Selection button to enter the parameters in line 3
- ④ Selection button to enter parameters in line 4

6.2 Information screen

The information screen appears for 2 seconds when the device is turned on.

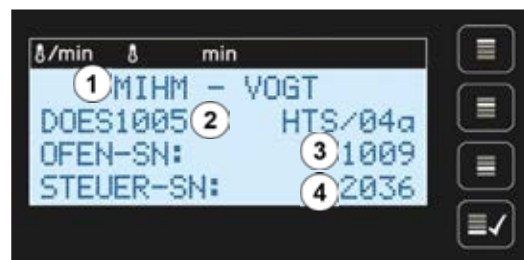

- ① Manufacturer
- ② Information on software and hardware status
- ③ Device serial number
- ④ Controller serial number



- ① Heating Rate (°C/min)
- ② Set final temperature of the stage (°C)
- ③ Set Holding Time of the Step (min)

6.3 Turn on the device

1. Connect the power supply.
2. Turn on the device using the main switch:
The standby screen (main menu) appears, after 3 seconds the current oven temperature will be displayed, the oven door opens automatically.



⌂/min	⌂	min	
99	0	0	BEREIT 1
99	0	0	23°C
99	0	0	MO 08:16
STUFE	1-3		MO 08:16

6.4 Basic settings program controller

During the initial startup, the device's default settings are preset for Germany. Other country-specific default settings can be entered following this menu scheme:

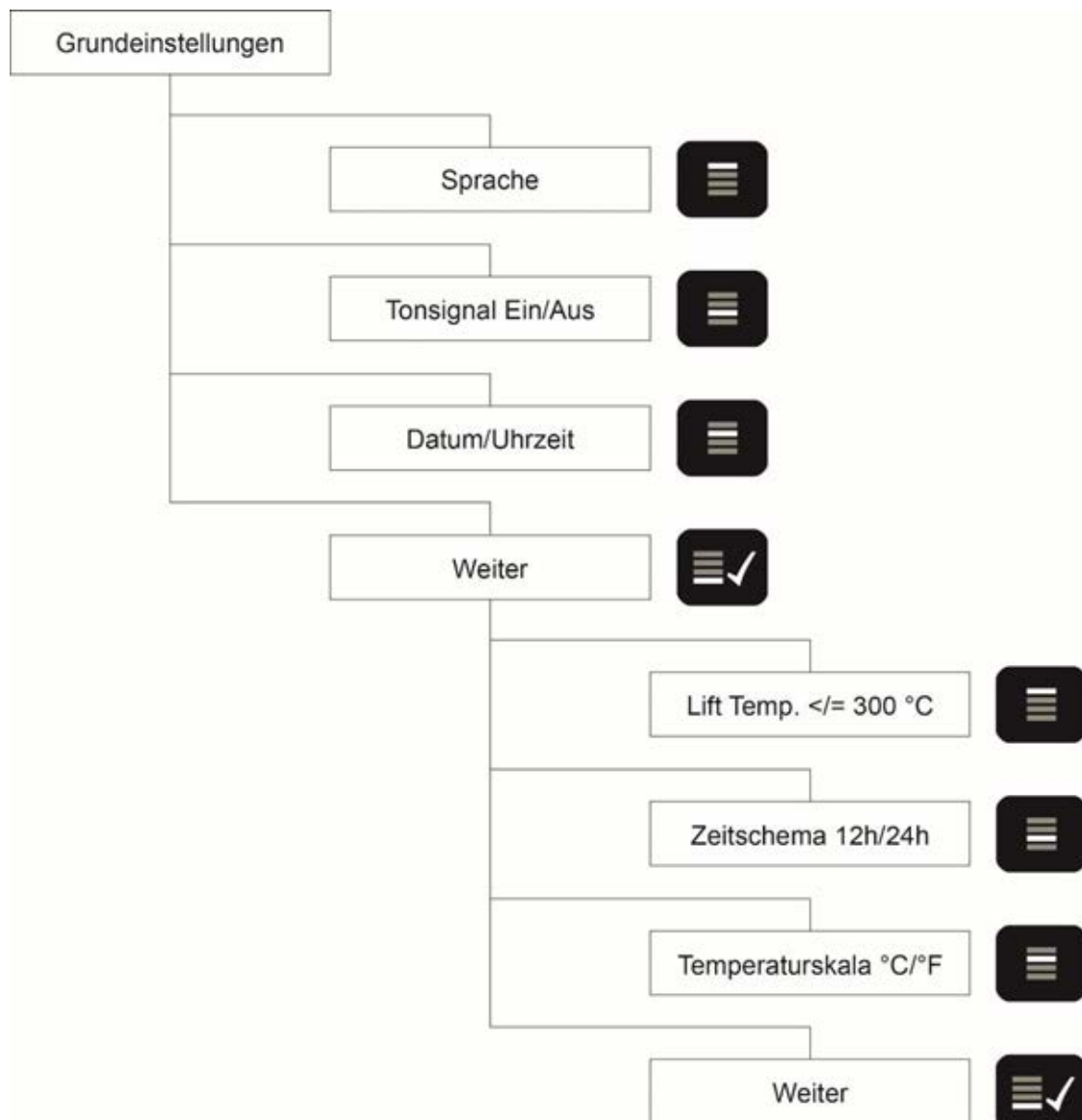

6.4.1 Switching the country-specific current limit from 15A to 13A

The current limit is factory-set to 15 A. To change it to 13 A, follow these steps:

1. Main Menu:

```

δ/min δ min
99 0 0|BEREIT 1
99 0 0| 23°C
99 0 0|MO 08:16
STUFE 1-3 |MO 08:16
    
```

F

2. Press the “F” key to open the “Settings” menu:

```

δ/min δ min
DEUTSCH
TON EIN
MO 08:16
WEITER
    
```

0-9

3. Enter the numeric code “7501” using the keypad and confirm by pressing the “Checkmark” button:

```

δ/min δ min
DEUTSCH
TON EIN
MO 08:17
7501 WEITER
    
```



```

δ/min δ min
COUNTRYCODE: 1
DEUTSCH 24h °C
15A
SPEICHERN
    
```

0-9

4. Enter the country code “02” using the numeric keypad:

```

δ/min δ min
COUNTRYCODE: 2
ENGLISH 24h °C
13A
STORE
    
```



5. Press the “Checkmark” button to save the settings. After successful saving, you will be automatically taken back to the main menu:

```

δ/min δ min
STORE
    
```

```

δ/min δ min
30 0 0|STNDBY 1
30 300 0| 23°C
30 980 60|MO 08:18
STAGE 1-3 |MO 08:18
    
```

6.5 Commissioning

6.5.1 Requirements for the executing personnel

The device must only be operated by trained professionals.

6.5.2 Safety instructions for operation

- Before use, the device must be checked for any damage.
- Every user must have carefully read and understand this operating manual.
- Safety instructions must be followed during operation, see section 1.7.
- Wear the recommended personal protective equipment.

6.5.3 Sinter aids

- Only use sintering aids approved by Mihm-Vogt.
- Please refer to the specific information leaflet of the sintering aids for application instructions.

6.5.4 Sintering

Load device



NOTE

- ▶ Avoid mechanical damage to the porous door insulation, which is sensitive to surface damage.
- ▶ Do not grab the door insulation with extraction pliers (or similar tools).



CAUTION

Risk of pinching your hands!

The oven door closes automatically.

- ▶ Press the "Start Stop" button only after the filled sinter bowl has been correctly placed on the support plate.
- ▶ Never reach into the area of the oven door and heating chamber while the oven door is moving. Make sure that no one reaches into this area.

1. Turn on the device using the main switch, the lift door will open automatically.
2. Fill the supplied sintering bowl with sintering granulate (fill height approx. 4-5 mm).
3. Place the sintered material into the sintering bowl.
4. Place the loaded sintered bowl or fleece pad as close to the center as possible on the support plate. If the heating chamber emits heat, use appropriate crucible tongs and heat-resistant gloves for safety.

Structure of the sintering programs

The 30 sintering programs are organized into 5 program groups, each with individually predefined program functions:

Progr. Place	Program Name	Linear Cooling	DCC*	Pre Drying	Ventilated Heating	Speed Cooling	Timer	
1-15	Standard	✓	✓				✓	
16-17	Pre Drying	✓	✓	✓			✓	
18-19	Ventilated Heating	✓	✓		✓		✓	
20-24	Speed Cooling	✓				✓		
25-30	Glaze	Getting Ready						

***DCC (Door Closed Cooling):** Cooling process with the elevator door closed (non-linear cooling curve).

Linear cooling/DCC

As the table shows, a linear cooling process can be activated in the first 3 program groups (program numbers 1-19). Unlike cooling with the door closed (Door Closed Cooling / DCC), the elevator door opens step by step during the cooling process, allowing for a linear cooling curve. To disable the linear cooling, simply enable DCC.



1. Load a program from group 1-19. Press the "Save Program" button, and the menu screen "DCC OFF" will appear.



2. If you want to carry out the linear cooling process with a gradually opening door, press the 'Checkmark' button. The program parameters will appear, and you can start the saved program right away.



3. If you have opted for "Door Closed Cooling" (DCC) instead of linear cooling, activate "DCC ON" using the line button 2, then confirm by pressing the "checkmark" button.

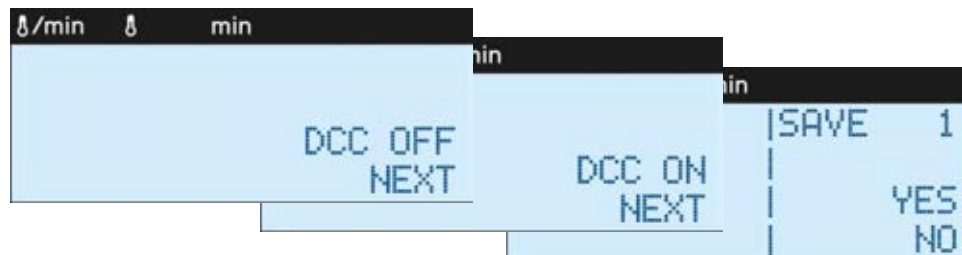

4. The "Save" menu screen appears. Press Line Key 2 to permanently save this setting along with the program parameters.

Tip: Whether DCC OFF or DCC ON is set for any of the programs 1-19 will be shown when you press the "Save Program" button again.



NOTE

The device enables linear cooling by automatically and gradually opening the lift door below 1200°C.

The lift door fully opens only after the program ends, or at the earliest time when the temperature drops below 800 °C.

Pre-Drying

For this program function, the following parameters are set for programs 16 and 17 for Pre Drying: The device heats up at a rate of 10°C/min to 200°C and then maintains this temperature for 60 minutes. Only the preset holding time can be changed by pressing line key 2 and entering the desired value via the numeric keypad.



↑/min	Δ	min	
99	0	0	STNDBY16
99	0	0	23°C
10	200	60	MO 08:18
STAGE 1-3			MO 09:36



NOTE

During the "Pre Drying" function, the lift door stays open throughout the entire holding time, and the radiant heat from the heating chamber, heated to 200 °C, creates an optimal drying temperature of about 58 °C at the restoration.

After this holding time has elapsed, the lift door automatically closes, and the sintering program starts.

Ventilated Heating

In programs 18 and 19, the "Ventilated Heating" function is permanently set and cannot be deselected. After loading one of these programs, entering the program parameters, saving, and starting, the lift door moves to about 5mm from the heating chamber and holds this position during the first heating stage or until reaching 1200 °C. After that, the lift door closes automatically, and the sintering program continues without any delay.



NOTE

The door position, slightly open during the initial heating phase, allows for increased oxygen supply to the heating chamber. This results in better color accuracy for certain zirconium materials.

Speed Cooling

For program slots 20-24, the "Speed Cooling" function is available. This feature automatically opens the door fully during the cooling phase at the end of the process, as predefined. This allows the cooling time to be sped up to the max. The heating and holding phases are programmed as usual. For the cooling phase, you don't need to enter any values since the lift door always opens fully automatically right after the last holding time ends.

Example of a single-stage program with Speed Cooling:

In this example, the elevator door fully opens at 1550 °C after the 5-minute hold time has elapsed.

Δ/min	Δ	min		
99	0	0	RUN	21
99	0	0	1523°C	
60	1550	5	MO 08:16	
STAGE 1-3			MO 09:36	



NOTE

Increased wear with speed cooling:

- ▶ Using the Speed Cooling function may cause an increase in cracks forming in the insulation.

After loading one of these programs and pressing the "Start Stop" button, the menu screen "Remove Sinter Tray!" (REMO VE SINTER TRAY!) will appear. Remove the sinter tray, use a cloth, and confirm by pressing the "Checkmark" button.



Δ/min	Δ	min	
REMO VE SINTER TRAY			
!			
ACCEPT			



CAUTION

Fire hazard!

Opening the lift door during "Speed Cooling" puts significant stress on the sintered shell due to the sudden temperature change.

- ▶ Please note the warning "Remove sinter shell" when starting any of the sintering programs 20 – 24 with the "Speed Cooling" function.
- ▶ Use sintered fleece with these programs.
- ▶ For added safety, use the optional and retrofittable protective cover "HTS-2 Protect to SPEED." You can find more information at www.mihm-vogt.de.

Sintering with Sintering Shell



NOTE

Recommendation for Using the Included Sintered Shell:

- ▶ For heating rates below 99°C/min, the supplied sintering bowls can be used.
- ▶ At heating rates above 99°C/min, there's a risk of damaging the sinter plate, so for these cases, we recommend using an optional sinter fleece instead of the sinter plate.

Select and load sintering program



1. Press the "Load Program" button. The most recently used heating program will be activated.

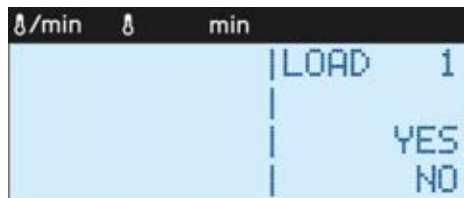

2. Press the "Select Display Line 4" button repeatedly until the desired heating program is reached or enter the desired program number directly using the numeric keypad.



3. Press the "Select Display Line 2" button for "YES" to confirm loading. The selected program along with the completion time (bottom right) will be displayed.

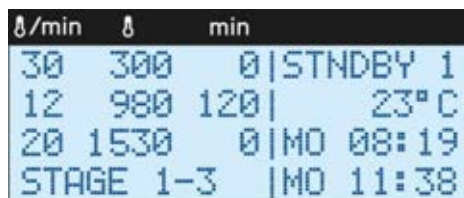

4. If you want to cancel loading, press the "Checkmark" button. The last displayed heating program will be shown again.

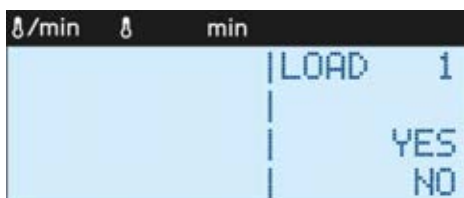

Start, pause, and stop the sintering program

Prerequisite: The device is loaded, and a heating program has been selected.



5. Press the "Start Stop" button. The oven door will automatically lift, and the heating program will begin. The left status LED will blink.

h/min	h	min		
30	300	0	RUN	1
12	980	120		23°C
20	1530	0	MO	08:19
STAGE 1-3			MO	11:38



6. If you want to pause or stop the sintering program, press the 'Start Stop' button again. The process will stop, the furnace door will automatically close (the temperature must be below 800 °C for this), and the standby screen will appear.

h/min	h	min		
30	300	0	STNDBY	1
12	980	120		23°C
20	1530	0	MO	08:19
STAGE 1-3			MO	11:38

Status LED

During the warm-up phase, the left LED blinks yellow:



During the holding phases, the left LED lights up yellow:



When the program ends, the right LED blinks green:



Remove sinter tray

After the sintering process is completed or aborted, the lift door is lowered.

1. Grab the hot sinter tray with a suitable crucible tong and carefully lift it off the support plate.
2. Place the sinter tray on a suitable heat-resistant surface.

Programming heat settings

When the device is switched on using the main power switch, the information screen appears first for 2 seconds, followed by the last program that was selected before it was turned off:

After the initial startup:

	Δ/min	Δ	min	
MIHM - VOGT				
DO				
OF	99	0	0	STNDBY 1
ST	99	0	0	23°C
	99	0	0	MO 08:16
STAGE 1-3 MO 08:16				

After turning on a gain, if a program has already been saved:

	Δ/min	Δ	min	
MIHM - VOGT				
DO				
OF	30	0	0	STNDBY 1
ST	30	300	0	23°C
	30	980	60	MO 08:16
STAGE 1-3 NEXT				

After turning off during the process and turning back on:

	Δ/min	Δ	min	
MIHM - VOGT				
DO				
OF	30	0	0	RUN 1
ST	30	300	0	48°C
	30	980	60	MO 08:19
STAGE 1-3 MO 10:33				

The controller allows programming processes with up to 9 steps.

Since the display has 4 lines, each menu screen shows 3 levels (ascending from bottom to top) and the currently visible range of levels (Level 1-3, Level 2-4, Level 3-5, etc.) is displayed in the bottom line.



With the "checkmark" button, the level display can be cyclically changed. Pressing this button shows the next level while the lowest one disappears. (1-3; 2-4; 3-5; 4-6; 5-7; 6-8; 7-9; 1-3; ...)



You can select the desired level for input using the respective line key, with the cursor blinking at the beginning of the line. Now, the preset "default values" (990 0) can be changed using the numeric keypad.

	Δ/min	Δ	min	
MIHM - VOGT				
DO				
OF	99	0	0	STNDBY 1
ST	99	0	0	
	99	0	0	
STAGE 1-3				
	30	300	0	STNDBY 1
	30	980	60	23°C
	25	1100	60	MO 08:16
STAGE 2-4 NEXT				

If no input is made within one minute while programming, the cursor disappears and a beep sounds. The device then enters standby mode. To return to the programming mode of the level, simply press the desired line button again.



1. Press the line key 2 (The cursor blinks at the beginning of the line in the input field "Heating Rate").



2. Enter the heating rate using the numeric keypad. The minimum heating rate is 1°C/min (2°F/min). The maximum heating rate is 120°C/min (248°F/min).

If the desired input value is only a single digit, you can start by entering two zeros (e.g., "005"), or you can simply enter the single digit (e.g., "5") and move the cursor to the next input field using the Enter key. When a three-digit value is entered, the cursor automatically jumps forward.



3. Now enter the 4-digit target temperature using the numeric keypad. The same rule applies here: If the target temperature has only 3 digits, start with a "0" and enter 4 digits or enter the desired 3-digit value and press the Enter key to jump to the next input field.



NOTE

The maximum achievable target temperature is 1650°C.

- ▶ If a higher value is entered, the display will automatically jump to the maximum value of 1650°C.
- ▶ If an invalid value is entered for the heating rate, the display will automatically reset to the default value (99 °C/min).



4. Now enter the 3-digit hold time using the numeric keypad.

NOTICE

The maximum programmable hold time is 999 minutes.

- ▶ If 4 digits are entered, the last digit entered will be ignored and the cursor will jump to the next field.



5. If you want to jump back to a previous input field, start at the beginning of the line by pressing the Enter key twice.



6. To program the additional heating levels, repeat stages 1 to 4 after you've jumped to the next desired level using the corresponding row button.



7. Once the first 3 levels are programmed, press the "Checkmark" button to move on to the 4th level. When this is programmed, press the "Checkmark" button again to display the 5th level, and so on.



NOTE

- ▶ If a program doesn't require all 9 stages, make sure that the target temperature for the unused stages is set to "0."
- ▶ All stages where the target temperature is set to "0" are ignored by the controller.

Save Sintering Program

You can store up to 30 programs. All saved programs remain intact even after the device is turned off.

The program is always saved under the program number it was previously loaded from.

Two distinct memory routines can be identified:

a) Program slots 1-19 (DCC OFF/DCC ON):



1. Press the "Save program" button.



2. Confirm by pressing line key 2.



3. Choose "DCC OFF" or "DCC ON" and confirm by pressing the "checkmark" button.



4. Press Line Key 2 "YES", the program has now been saved.

b) Program slots 20-30:



1. Press the 'Save Program' button.



2. Confirm by pressing the line key 2 "YES."

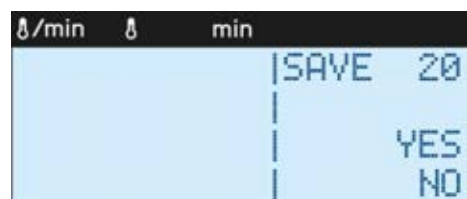

3. If you want to cancel the save operation, press the "checkmark" button labeled "NO."

Save heating program with name

To clearly and personally identify a specific heating program, it can be saved under a custom name:



1. Press the 'Save Program' button.



2. Press the function key "F" to change the first letter of the desired program name. Repeatedly pressing these key cycles through the alphabet from A to Z. Numbers can also be entered using the numeric keypad.



3. Press the line key 4 to jump to the next letter. Continue with the remaining name letters in the same way until the desired program name is fully displayed. For naming, you have the entire left input field at your disposal, which consists of 4 lines with 11 letters each (a total of 44 letters). You switch lines by pressing the line key 3. To jump to the next line, you can also press the line key 4 twelve times.



4. To save, confirm by proceeding after naming is complete "Checkbox."

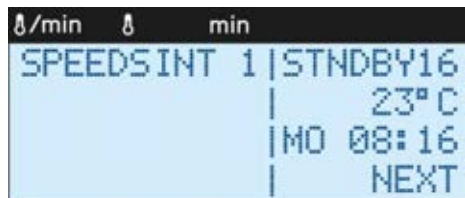

5. The menu screen "SAVE 1" appears. To save the program, press line button 2 "YES." To cancel saving, press the "Checkmark" button "NO."

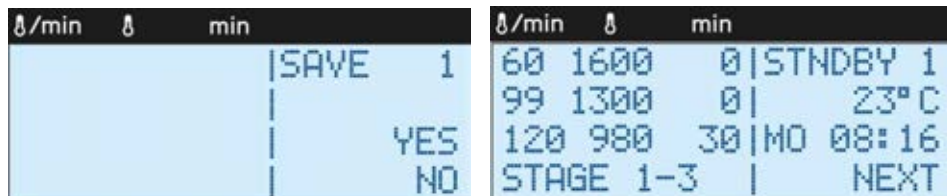

6. To start the program right away, press the "Start Stop" button: The process screen will appear, and the program will begin. The temperature display on the screen (line 3, right side) continuously shows the temperature changes.

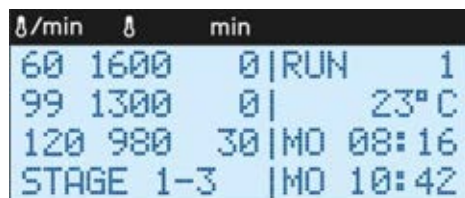

6.5.5 Autostart timer function

The device can be programmed via an internal timer so that the currently loaded program automatically starts based on the entry of the desired completion time (finish time). The finish time is set by specifying the preferred day of the week and time.

Proceed as follows:



1. Download the desired program.



2. Press the "Autostart Timer" button. The "Autostart Timer" menu screen will appear.

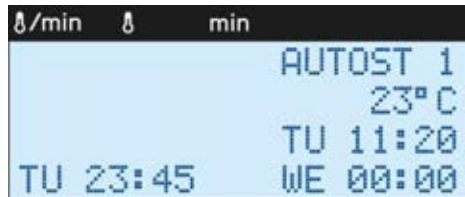

3. Press the "Checkmark" button to enter the day of the week. Use keys 1 – 7 (numeric keypad) to set the weekdays (1 = Monday, 2 = Tuesday, 3 = Wednesday, etc.). After entering, the cursor will automatically move to the hours field.



4. Set the hour using the numeric keypad. After entering two digits, the cursor will jump to the minutes field.



5. Enter the minutes using the numeric keypad. Once you input two digits, the programming is complete.

6. The start time is automatically calculated and displayed. This means the auto-start timer is now activated.

- ① = current time
- ② = set completion time
- ③ = calculated start time
- ④ = Autostart enable

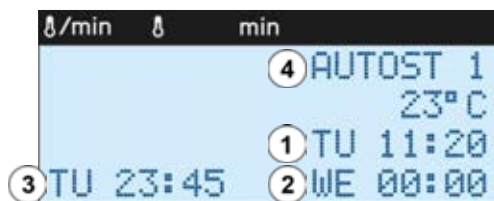

7. Disable the auto-start function by pressing the "Auto Start Timer" button again.

6.5.6 Loading and renaming saved programs

Load heating program



1. Press the "Load Program" button, and the "Load Program" menu screen will appear. The dial loads the most recently used program.

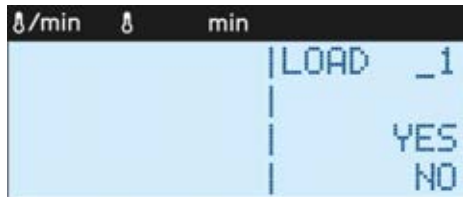

2. Pressing the line button 4 lets you scroll through the program list (program slots 1-33). Select the desired program number (here 1).



3. Press the Line Key 2 "YES" to confirm loading, the standby screen will appear:

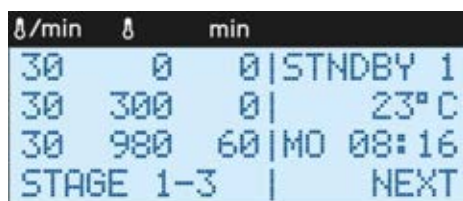

4. If you want to cancel the loading, press the "checkmark" button labeled "NO."

Save or rename program with program name



1. Load the program to be renamed (unless it's the most recently used one).

2. The program is displayed **1**. If a name was already assigned, it will appear in the left text box **2**:



3. Press the 'Save Program' button and confirm by pressing the 'Checkmark' button (for program slots 1-19) to access the 'Save Program' menu screen. For program slots 20-30, the save menu appears directly.

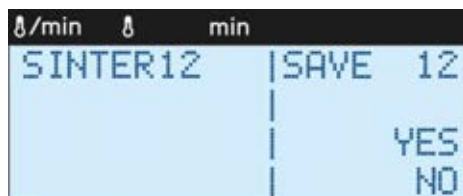



4. The cursor is now blinking on the first letter of the name (top left).



5. The function key "F" can be used to change or enter a letter, the numeric keypad allows numbers to be entered, the row key 4 selects the next letter position, and the row key 3 selects the next line.

The entire left text box is available for the program name (4x11 letters or digits):

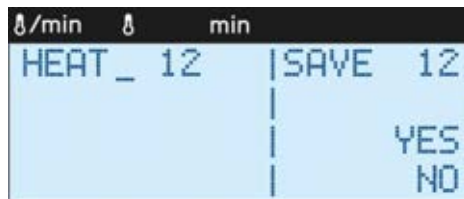

6. Press the enter key to confirm saving; the program is now saved under the new name at the specified program slot.

NOTICE

The program slot number cannot be changed.

- ▶ If you want to save a specific program to a different program slot, you first need to call up the desired program number, enter or change the parameters, and save the program. Since the previous values will be overwritten, they will be lost.



HINWEIS

Use of coloring liquids affects the unit's service life!

During the sintering process, the use of coloring liquids can significantly shorten the service life of the heating elements.

6.5.7 Service programs

A cleaning cycle should be run periodically depending on how often the oven is used. This serves to remove contamination due to liquids and other impurities that become deposited in the insulation.

Depending on the frequency of use, a regeneration cycle should also be carried out, which is necessary for regeneration of the heating elements.

Service programs can be selected on program slots 31-33:

- 31: Service A – Temperature control
- 32: Service C – Heating chamber cleaning
- 33: Service E – Heating element regeneration

7 Declaration of conformity



EC Declaration of Conformity in accordance with Machinery Directive 2006/42/EC
Annex II 1.A

The manufacturer/distributor

MIHM-VOGT GmbH & Co. KG
Friedrich-List-Str. 8
76297 Stutensee, Germany
Tel.: +49 (0) 72 44/7 08 71-0
Fax: +49 (0) 72 44/7 08 71-20
E-mail: info@mihm-vogt.de

hereby declares that the following product

Product designation: Sintering furnace
Series/type designation: HTS-2/M/ZIRKON-120

Description:
The HTS-2/M/ZIRKON-120 sintering furnace is high-temperature furnace for commercial use in dental laboratories for sintering sinterable ceramics.

complies with all relevant provisions of the above Directive and of the additional Directives applied (see below) – including all changes to these Directives that are valid at the time of this declaration.

The following additional EU Directives have been applied:
EMC Directive 2014/30/EC
RoHS Directive 2011/65/EU
The safety objectives of the Low Voltage Directive 2014/35/EC have been complied with.

The following harmonised standards have been applied:

EN 61010-1:2010	Safety requirements for electrical equipment for measurement, control, and laboratory use – Part 1: General requirements (IEC 61010-1:2010)
EN 61010-2-010:2014	Safety requirements for electrical equipment for measurement, control, and laboratory use – Part 2-010: Particular requirements for laboratory equipment for the heating of materials (IEC 61010-2-010:2014)
EN 61326-1:2013	Electrical equipment for measurement, control and laboratory use – EMC requirements – Part 1: General requirements (IEC 61326-1:2013)
EN ISO 12100:2010	Safety of machinery - General principles for design - Risk assessment and risk reduction (ISO 12100:2010)

The following national or international standards (or parts/clauses thereof) and specifications have been applied: -

Name and signature of the person who is authorised to compile the technical documents:
Achim Apfel

Place: Stutensee
Date: 23.06.2017



(Signature)
Dietmar Gräbe



This product bears the CE mark in accordance with the Provisions of Directive 2006/42/EC (Machinery Directive).

We declare conformity for the device HTS-2/M/ZIRCON-120 based on the following standards:

- Safety: EN 61010-1:2010 and EN 61010-2-010:2014
- EMV: EN 61326-1:2013
- Risk Assessment and Risk Reduction: EN ISO 12100:2010



RoHS Compliance

RoHS compliance confirms that the device is free of hazardous substances, meaning all legally valid limits are met. The device must not be carelessly thrown away but instead must be taken to a recycling system, see section 1.15.4.



EAC Certification

Conformity Mark of the Eurasian Economic Community
Certificate number EAC N RU Д-DE.A475.B.02156

8 Care and maintenance



DANGER

Electric energy! Danger of fatal electric shock.

- ▶ Work on electrical systems may only be performed by qualified electricians.
- ▶ Before performing maintenance, cleaning, or repairs, disconnect the device from its power supply and secure it to prevent accidental reactivation.
- ▶ Do not touch live cables and components with wet hands.
- ▶ Observe the accident prevention regulations when handling electric current.



WARNING

Hot surfaces! Severe burns possible.

- ▶ Always let the device cool down completely before performing maintenance, cleaning, or repair work.
- ▶ Wear heat-resistant, thermal-insulated safety gloves when working on hot components.



NOTE

- ▶ Before working on the device, every operator must have read and understood the operating manual.
- ▶ The user manual must be kept for the entire lifetime of the device.
- ▶ Always wear personal protective equipment when working on the device.



8.1 Requirements for the Operating Personnel

Maintenance and repairs must only be carried out by trained professionals.

8.2 Maintenance Schedule

Components:	Interval:	Person in Charge:
Power connection cable, power supply connection	monthly	Operator
Cooling Fan	before each use	Operator
Heating chamber interior	before each use	Operator
Vacuum the inside of the heating chamber	monthly	Operator
Rekindling Fire	quarterly (depending on the application)	Operator

9 Malfunctions and error messages



DANGER

Electric Power!

Danger of fatal electric shock.

- ▶ Work on electrical installations may only be carried out by qualified electricians.
- ▶ Before starting installation, maintenance, cleaning, or repair work, disconnect the device from its power source and lock it out to prevent it from being switched back on.
- ▶ Do not touch live cables and components with wet hands.
- ▶ Please observe the accident prevention regulations when handling electric current.



WARNING

Hot surfaces!

Severe burns possible.

- ▶ Do not touch the housing and the device door during operation.
- ▶ Always let the device cool down completely before performing maintenance, cleaning, or repair work.
- ▶ Wear heat-resistant, thermal-insulated safety gloves when working with hot components.



NOTE

Property damage due to inadequate repairs to electrical cables!

Malfunction or damage of electrical components possible.

- ▶ Never repair faulty cables or plugs; always replace them.

9.1 Malfunctions

Failure	Possible Cause	Troubleshooting
Wrong time	Time was saved incorrectly in the controller	Set the time correctly. If this error happens again, the CR 2032 button cell on the control board needs to be replaced.
The sintering furnace doesn't start automatically	Power outage / Interruption of electricity supply	Check the power supply for interruptions; if necessary, notify a qualified electrician.
No display on the screen, status LEDs do not light up	No power supply available	Check the customer-side fuses. Inspect the connection cable, and if needed, contact a qualified electrician.
Pieces of the door panel have broken off; other damage to the door panel	Improper handling of the door panel	Replace the turf filling.
No display, or the status LED briefly lights up when turned on	faulty display	Replace the rules.

9.2 Electronics error messages

Error Message	Possible Cause	Troubleshooting
F20 Display "Network interruption"	Network interruption / Circuit breaker has tripped	Check the power supply, replace the fuse. To clear the error, press the "Start Stop" button.
F30 Display: "Thyristor Fault"	Error messages appear quickly: Fault in the controller electronics	Contact Mihm-Vogt Service.
	Error message appears with delay: Fault in the heating circuit	Contact Mihm-Vogt Service.
F41 Display "Sensor Fault"	Faulty Thermocouple	Replace the thermocouple, contact Mihm-Vogt Service.
	Thermocouple connections loose	Tighten the screws on the thermocouple connections.
F43 Show "Sensor + <-> -"	Thermocouple polarity reversed after replacement	Pay attention to the labeling on the thermocouple and connect the + terminal to the orange wire.
	Polarity reversal at the controller after replacement	Pay attention to the label on the controller and connect the + pole to the orange cable.
F71 Safety Shutdown Display	Furnace temperature rises above 1650 °C	To prevent the device from overheating, it automatically shuts off at 1680 °C. Be sure to contact Mihm-Vogt Service!

10 Technical drawings

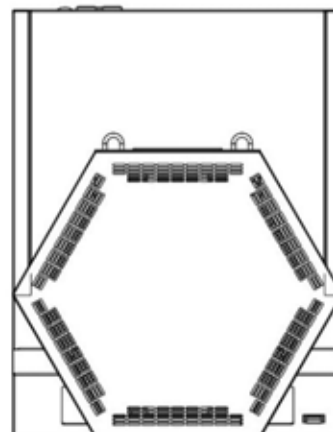
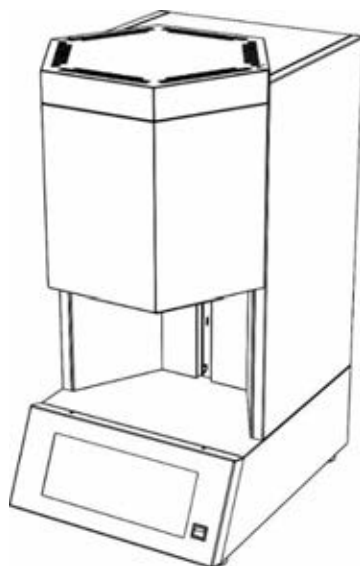
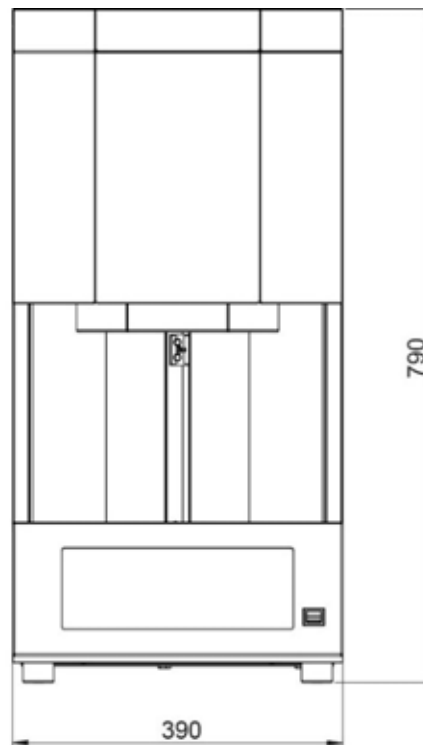
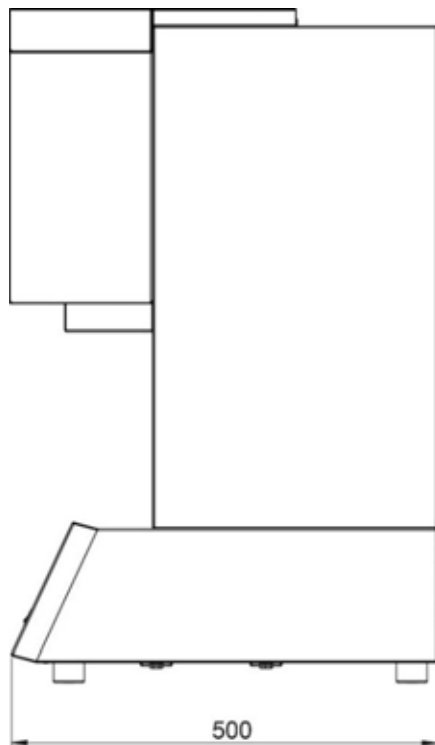

All dimensions in mm

Device weight: 60 Kg